

## 2.5 Litre Double Lock TTE Range

### Container

<b>Order Code:</b>	NXOPDL0250
<b>Description:</b>	2.5 Litre Round
<b>Brimful Volume:</b>	3.35 Litres
<b>ISO Volume:</b>	3.10 Litres
<b>Tamper Evident:</b>	Yes

### Material

<b>Tub:</b>	Polypropylene
<b>Lid:</b>	Polypropylene
<b>Handle:</b>	Polypropylene / Metal

### Weight

<b>Tub:</b>	105 grams
<b>Lid:</b>	30 grams
<b>Handle:</b>	5 grams / 22 grams

### Performance

<b>Storage Temperature:</b>	0°C - 40°C*
<b>Shelf Life:</b>	Minimum 12 months
<b>Static Load on bottom Pail:</b>	Maximum 23 kg at 20°C
<b>Suitable for Hot Filling:</b>	Yes* (Above 70°C See note)
<b>Suitable for Tinting:</b>	Yes

### Compatibility

Some chemicals, and process parameters, can affect the integrity of the container. The buyer must undertake testing and approval for the container's suitability for the product and application.

### Regulatory

Raw materials used are REACH compliant, approved for food contact and meet FDA regulations.

Standard tolerance of ±5%

\*Special blends and additives available for non standard conditions.

Specifications can be modified without notice; please contact your OnePlastics representative to ensure you have the most recent information.

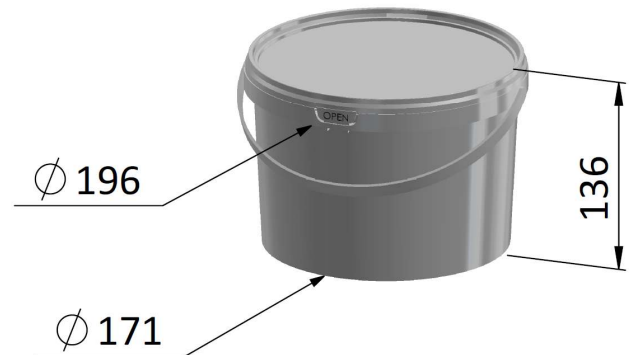

### Decoration

<b>Tub IML:</b>	Yes
<b>Lid IML:</b>	No
<b>Colours:</b>	White, others on request

### Palletisation

<b>Lid Pallet Quantity:</b>	4200
<b>Bucket Pallet Quantity(Empty):</b>	1230
<b>Units per layer:</b>	30
<b>Bucket Pallet Quantity (Filled):</b>	210

